



**SAYKAL**

**Tire Pressure  
Monitoring System**

Sensor Technologies

TPMS



# Tire Pressure Monitoring System

## Sensor Technologies

### TPMS



### Product Overview

SAYKAL TPMS; It is an innovative, robust and reliable electronic pressure control unit developed for the automotive industry and includes new generation technologies. It is customized for tire pressure monitoring. It is a high-performance short-range RF sensor operating at frequencies of 315 MHz - 433 MHz for in-tire pressure, temperature and acceleration applications. It provides 125kHz LF communication for configuration. TPMS evaluates tire data collected from different directions and notifies drivers in advance of potential negative consequences.

### Hardware Features

- 12V - 24V DC
- Reverse Connection Protection
- Overvoltage Protection
- CAN
- LIN
- Ignition Input
- 2 x Output & 2 x Input
- IP67 Protection
- EBS Connecting Cable

### Software Features

- Tire pressure by wheel location
- Temperature compensated pressure sensing
- High pressure / Low pressure warning
- High temperature warning
- Spare tire monitoring
- Sensor Modes(Ship, Park, Drive)
- Learning
- Communication up to 15m
- Compatible J1939 & ISO 11992

### Functional Block Diagram

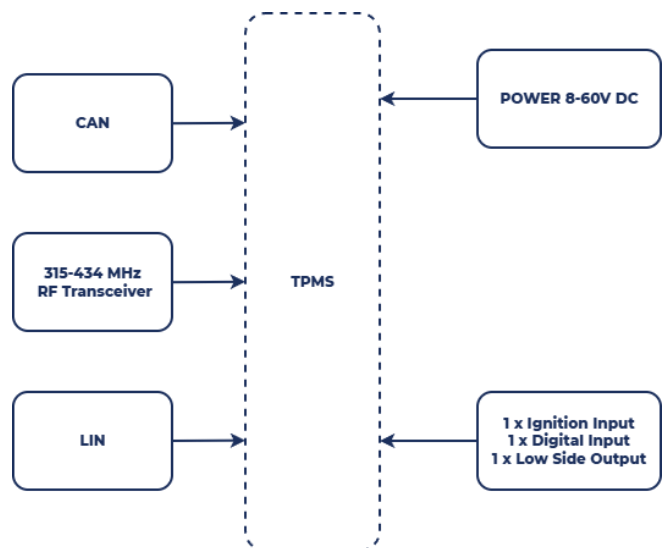



# Tire Pressure Monitoring System

## Typical Application Features – TPMS

- Detection of movement in Radial and Tangential directions
- Transition between modes by detecting movement (Park-Drive)
- At least seven years of lifetime
- Diagnostic tool connection
- User configuration
- Fault diagnosis
- The system powers up when the ignition is turned on.
- Capability of CAN-Bus features
- General Safety Regulation (GSR) ECE R141 compliant (Europe)
- **AUTO-LOCATION:**
  - Automatic location of all tire sensors to correct wheel positions, eliminating need for manual programming of tire sensors.
- **TIRE FILL ASSIST:**
  - Allows vehicle operator to fill tire to exact, temperature compensated, pressure rating.
  - Removes the need for a separate pressure gauge.
- **TIRE LOCK WARNING:**
  - Warning when a tire does not rotate
  - Can be combined with a lowered position of a tag / lift axle
- **TIRE BURST WARNING:**
  - Detects fast pressure drop caused by tire blow out
  - Sends a warning signal, including specific tire location
  - Allows for vehicle reaction control upon a tire burst event

## Sensor – TPMS

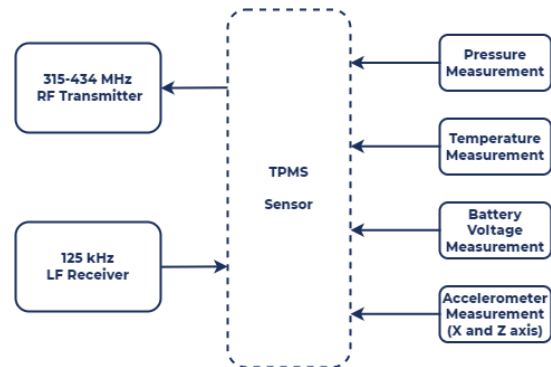

## Hardware Features

- 90 - 1518 kPa
- -40 - 125 C
- -360 - 400g Z axis (Radial)
- -80 - 90g X axis (Tangential)
- 9+ years
- Dual frequency 315/433 MHz Transmitter
- 125 kHz Receiver
- All Rim Compatible
- Pressure Sensor
- Temperature Sensor
- Acceleration Sensor
- Tire Turn Direction
- Low Battery Status



# Tire Pressure Monitoring System

## Sensor Features

- With Sensor mounted directly to the rim, Tire ID programming enables vehicle to adjust performance and handling to match the installed tire
- LF enabled sensors
- Sensors with LF technology enable Over the Air Updates (OTA) to add additional features and capabilities after vehicle is already in the field, as well as making remote tire information traceability for warranty purposes more effective
- Designed to last the life of the tire
- Programmable with Tire Details (ID) or new Advanced Features
- Optimized design enables battery to last the life of a tire

## Diagnostic Tool Features

SAYKAL TPMS tool is a professional matching tool for tire pressure maintenance. Intuitive navigation design, clear interface display, ergonomic product structure, convenient operation, simple and easy to understand. It can activate tire pressure sensors of different frequencies, with strong signals, and can read real-time data of tire pressure sensors, including tire pressure, temperature, battery status, etc. It also has powerful functions such as programming sensors, tire pressure fault diagnosis, and tire pressure matching learning. , is your professional assistant for tire pressure maintenance matching.

- Dual frequency 315/433 MHz Transmitter and Receiver
- Activate and read Tire Pressure Monitoring System (TPMS) sensor data, program sensors and display sensor data in seconds (ID, tire pressure, tire temperature, battery status, etc.)
- Full database of indirect, manual and auto relearn procedures
- Intuitive, full-color display with easy vehicle lookup by make, model and year

Saykal TPMS tool is a new generation complete TPMS tool that offers the option to choose one of two service modes from the home screen, to provide faster and smarter TPMS repairs. Based on the TPMS service type needed, the option to choose the basic Quick Mode or the complete Advanced Mode will decrease repair time.

- TPMS Quick Mode: basic TPMS functions to check TPMS sensors and program MX-Sensors quickly.
- TPMS Advanced Mode: complete TPMS functions to perform sensor check , TPMS diagnose, Saykal TPMS sensor program and sensor position relearn.

## Exclusive TPMS Status Screen



- Read ECU sensor ID.
- Check sensor ID and ECU ID matching condition.
- Read DTCs from ECU and erase DTCs.
- View DTCs detail description.

\*Final design work continues.



# Tire Pressure Monitoring System

## Functional Block Diagram – Diagnostic Tool

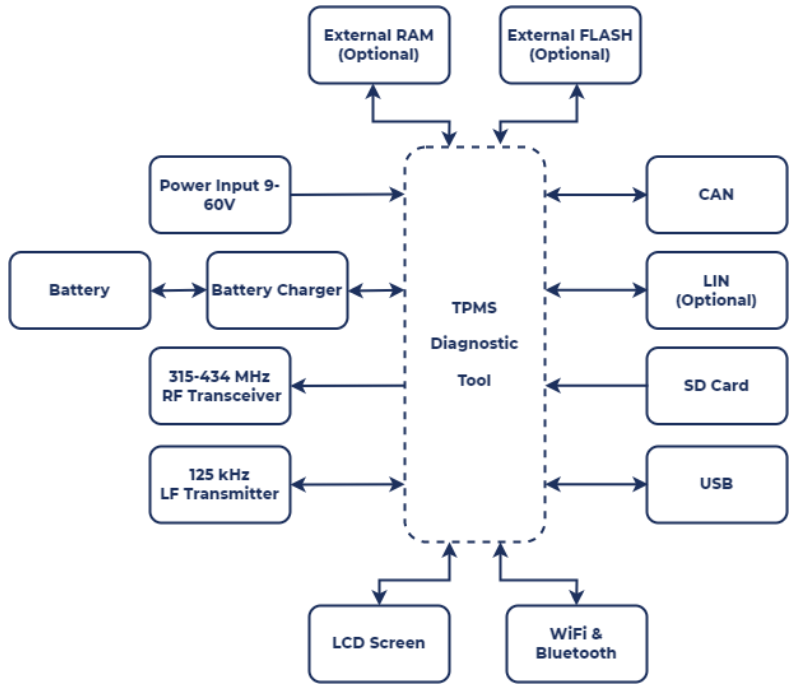

## Application Example on Vehicle

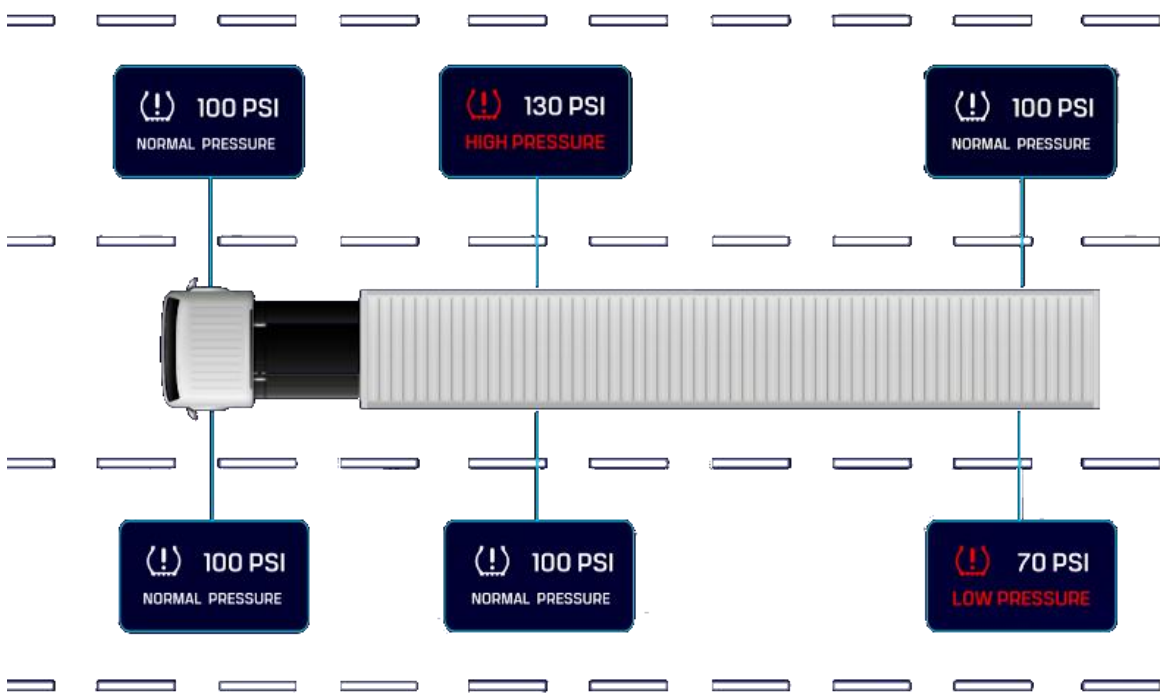



# Tire Pressure Monitoring System

## Package Outline and Branding Drawing

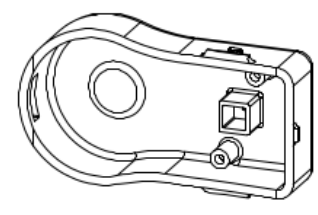
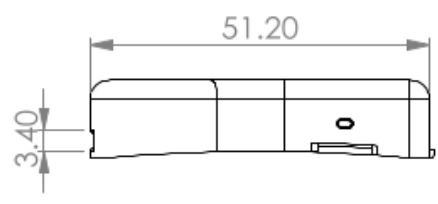
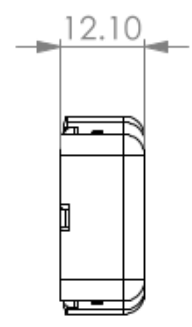
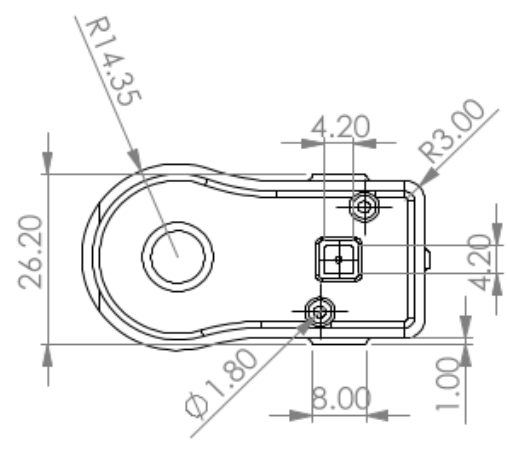
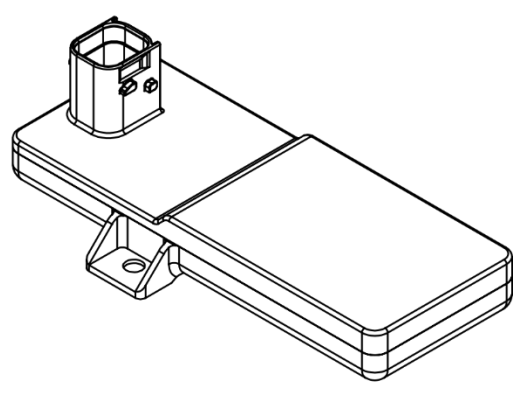
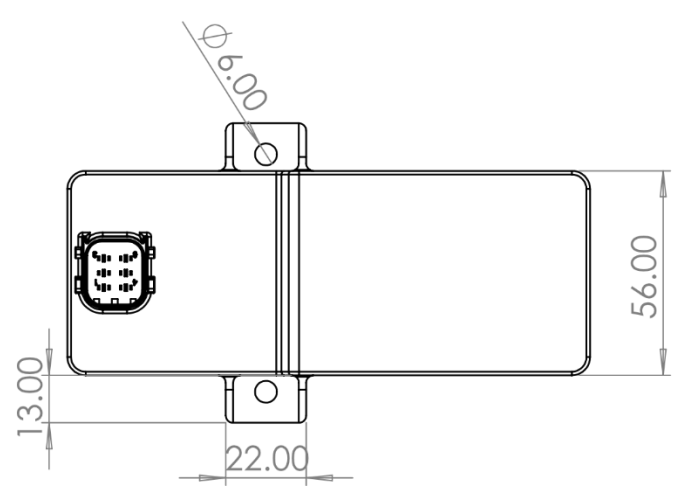
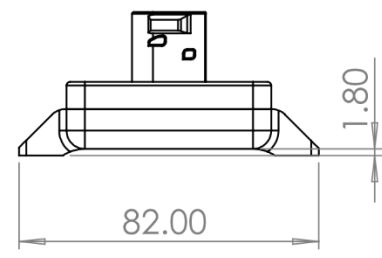
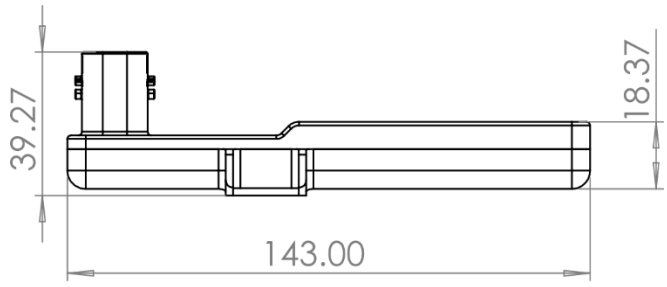



# Tire Pressure Monitoring System

## Pin Out / Pin Names and Descriptions V1

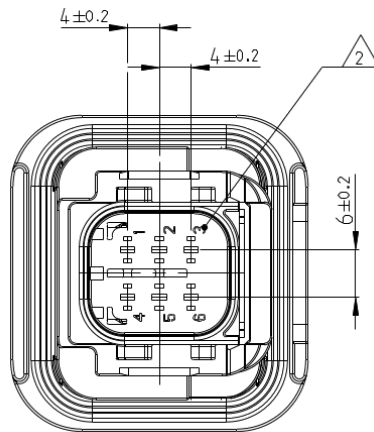

1-1703820-1

PIN	NAME	DESCRIPTION
1	KL30	Supply Voltage, 8V / 40V
2	CAN High	CAN Communication
3	CAN Term	CAN Termination
4	KL31	Chassis Ground
5	CAN L	CAN Communication
6	KL15	Ignition Input ( Active High)



# Tire Pressure Monitoring System

## Important Notice

The information contained herein is believed to be reliable; however, Saykal makes no warranties regarding the information contained herein and assumes no responsibility or liability whatsoever for the use of the information contained herein. All information contained herein is subject to change without notice. Customers should obtain and verify the latest relevant information before placing orders for Saykal products. The information contained herein, or any use of such information does not grant, explicitly or implicitly, to any party any patent rights, licenses, or any other intellectual property rights, whether about such information itself or anything described by such information. THIS INFORMATION DOES NOT CONSTITUTE A WARRANTY WITH RESPECT TO THE PRODUCTS DESCRIBED HEREIN, AND SAYKAL HEREBY DISCLAIMS ANY AND ALL WARRANTIES WITH RESPECT TO SUCH PRODUCTS WHETHER EXPRESS OR IMPLIED BY LAW, COURSE OF DEALING, COURSE OF PERFORMANCE, USAGE OF TRADE OR OTHERWISE, INCLUDING THE IMPLIED WARRANTIES OF MERCHANTABILITY AND FITNESS FOR A PARTICULAR PURPOSE. Without limiting the generality of the foregoing, Saykal products are not warranted or authorized for use as critical components in medical, lifesaving, or life-sustaining applications, or other applications where a failure would reasonably be expected to cause severe personal injury or death.

Copyright 2011 © Saykal, Inc. | Saykal is a registered trademark of Saykal, Inc.



[www.saykal.com](http://www.saykal.com)